

OurAir SQ 500

Features & Functions

OurAir SQ 500

Technical Information



DIMENSIONS



SOUND OUTPUT

Noise level at various distances and directions at fan speed level 3.

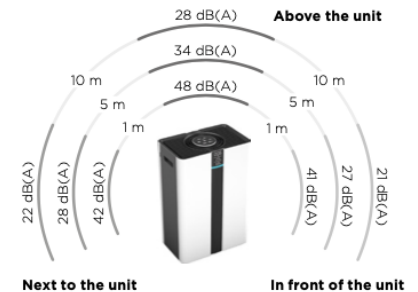

OurAir TK 850

Features & Functions

OurAir TK 850

Technical Information

MOBILE AIR PURIFICATION SYSTEM

PIN-protected 7" touchscreen with operation controls and a filter condition indicator.

Individually-tested **HEPA H14¹ filters** capture more than **99.995%** of viruses, bacteria and micro-organisms.

Optional **ozone-free UV-C stage**

Fine dust prefilter as standard **with an activated-carbon layer** to eliminate odors, ozone, NO₂ and VOCs available **as an option**.

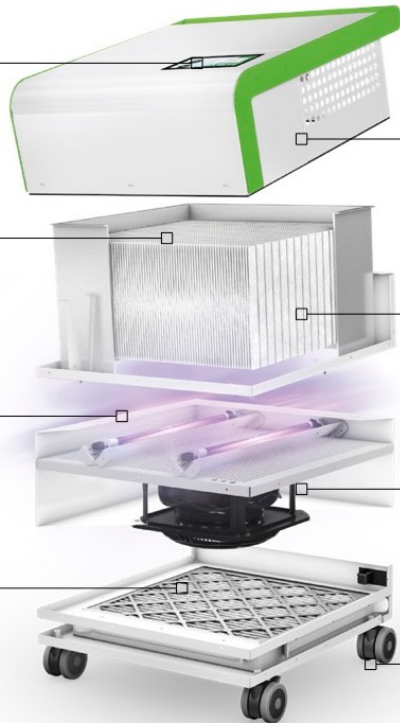

Steel cabinet is powder-coated in a neutral finish.

Optimized system and filter media design for a **low power consumption**.

Quiet motor and an optimized air flow provide **outstanding performance**.

Smooth-running wheels and **foot-operated brakes** make it easy to position TK 850 accurately and safely.

DIMENSIONS & LAYOUT

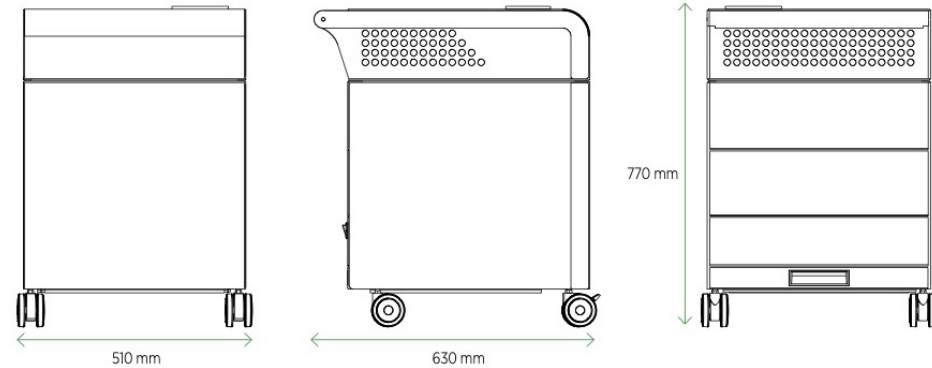

OurAir SQ 2500

Features & Functions

OurAir SQ 2500

Technical Information

MOBILE AIR PURIFICATION SYSTEM

PIN-protected 4.3" touchscreen with operation controls and a filter condition indicator.

Optional **ozone-free UV-C stage**

Individually-tested **HEPA H14¹ filters** capture more than **99.995%** of viruses, bacteria and micro-organisms.

Fine dust prefilter as standard with an **optional activated-carbon** layer to eliminate odors, ozone, NO₂ and VOCs.

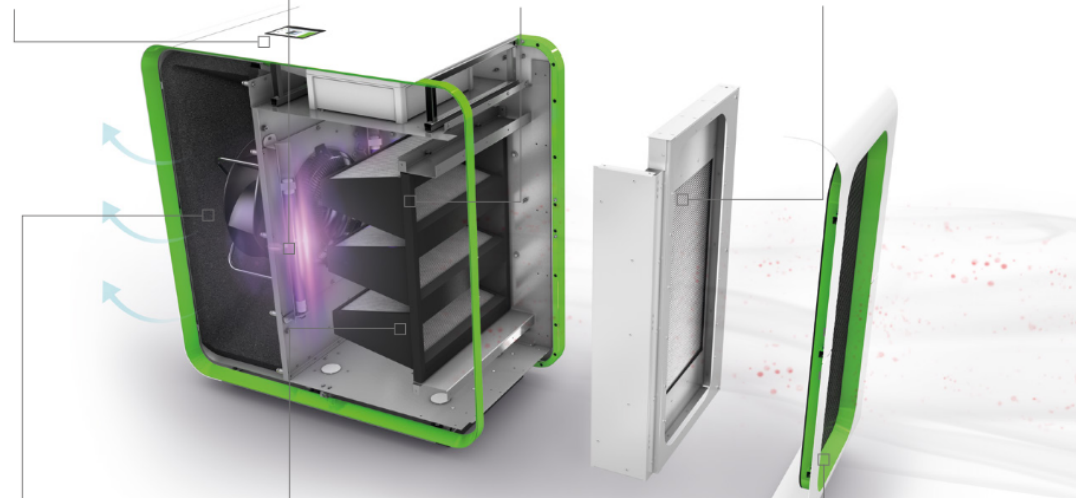

Quiet motor and an optimized air flow provide **outstanding performance**.

Optimized system and filter media design for a **low power consumption**.

Steel cabinet is powder-coated in a neutral finish.

DIMENSIONS & LAYOUT

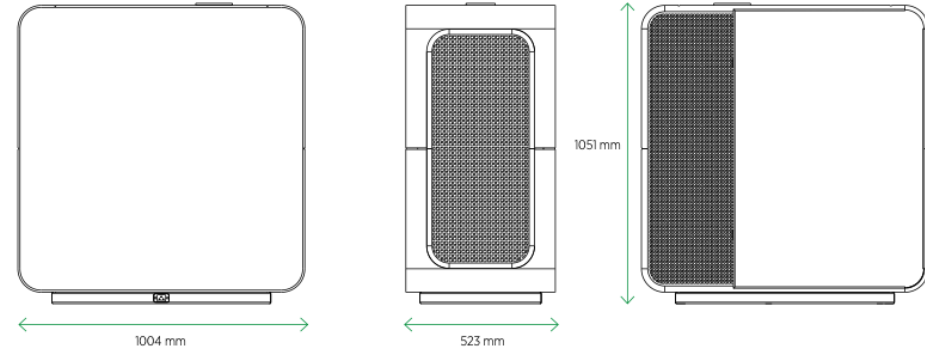



SOUND OUTPUT

Noise level at various distances and directions with an air flow of 1,250 m³/h and a damper fitted.

